

The background of the image is a semi-transparent view of an industrial factory. It features a high ceiling with a grid of structural beams and several bright overhead lights. A prominent yellow overhead crane system spans across the top of the frame. In the lower right, a robotic arm with a gripper is visible, positioned to handle a long, white cylindrical component. The overall scene conveys a sense of modern manufacturing and automation.

SPN JIT Engineering Solution Pvt Ltd

Our Partner

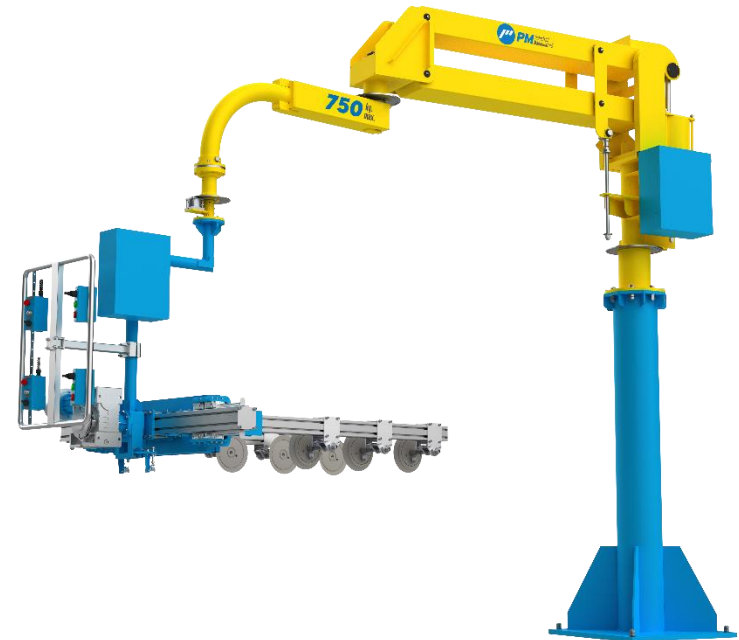

About SPN JIT



SPNJIT ENGINEERING SOLUTIONS is a well established organization being managed by professionals holding 25 years of rich technical experience in a diversified industries. We are engaged to provide engineering services of Material Handling Equipment, automation & Sheet Metal Cutting, Fabrication, Machining .

SPNJIT strives to be a technical, problem solving partner specializing in material handling solution. We are served a variety of industries like Automotive, General Engineering, Auto Component, Construction Equipment, FMCG, Forging & Casting, Steel, Defense and many more .

SPNJIT ENGINEERING SOLUTIONS PVT. LTD. a blend of " Rich professional experience together with new set of machines as start-up" is delivering to customers as agreed in terms of cost, quality and timely delivery.

We believes in continuous improvement based on feedback.

We have a team of young, energetic, innovative & capable engineers for designing, development, manufacturing, erection & commissioning to meet the customer's requirements. We are equipped with In-house facility of Design, Complete Tool Room, Quality Control, Painting, Welding, Assembly, Electrical & Programming.

We have established ourselves for over a decade due to our commitment, quality, customer satisfaction & services.

We are one of the leading turnkey solution provider of material handling overhead cranes like; X Y Friction Free Rail systems , Mono Rail systems, Jib cranes (Pillar Mounted / Wall Mounted), Gantry Systems, Manipulators , Conveyor & customized solutions as per requirement.

History



- October 2018 SPN JIT Engineering Established.
- March 2019 Take Over with JN Robotics Pvt Ltd (Automation & Material Handling Division).
- October 2020 Take over Saber Dais Compression Ltd.
- March 2021 Take over Kunta International Ltd (Heat sink Division).
- April 2020 Take over Krishna Automation.

Line of business

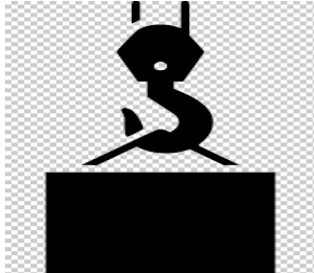

Material Handling

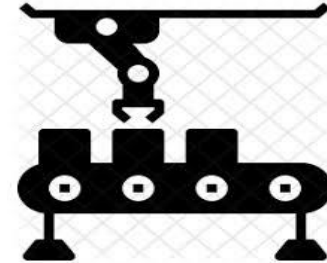

Process Automation

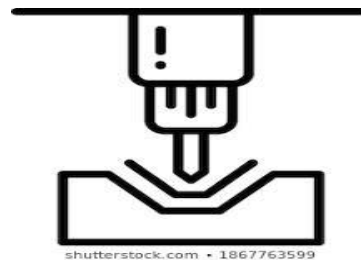

Machining & Fabrication

Why SPN JIT

Strategic partnership (Safety & Reliability)

24 * 7 Service & Support

Ease of business - hierarchy access & decision faster.

Stability

Customized Solution



Sector we serve

Automobile

Agriculture Equipment

Construction Machinery

Auto Components

Pumps & Valves

General Engineering

Electrical and Switchgear

Foundry & Forging

Tire & Rubber

Cables & Wire

Our Infrastructure



- Laser Cutting Machine 2 Nos.
- Laser Welding 1 No.
- VMC Machine 2 Nos.
- CNC Machine 2 Nos.
- Bending Machine 100 Ton 1 No.
- Power Press 1 No.
- Milling Machine 4 Nos.
- Lathe Machine 4 Nos.
- Bandsaw Metal Cutting 2 Nos.
- Spot Welding 1 No.
- Welding Machines 12 Nos.
- Surface Grinder 2 Nos.
- Tapping Machine 6 Nos.
- Buffing Machine 2 Nos.

Solution offer

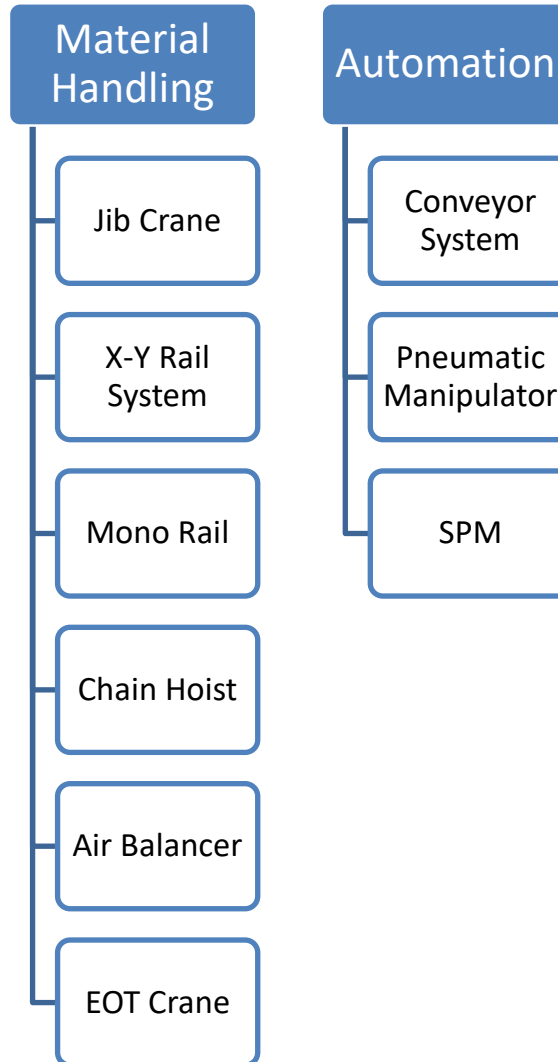

X-Y Rail System



Product Range

Capacity : 125 Kgs to 2 Ton

Span : 8 Mtr.

Material : MS / Aluminum

Hoist : Chain Hoist

Speed Type : Single Speed/ Double Speed

Power Supply: Festoon System / Busbar System



Mono Rail System



Product Range

Capacity : 125 Kgs to 2 Ton

Hoist : Chain Hoist

Speed Type : Single Speed/
Double Speed

Power Supply: Festoon
System / Busbar System



Product Range

Capacity : 0.125 to 3 Ton

Span : 6 Mtr.

Slewing : 360 Deg.

Hoist : Chain Hoist

Speed Type : Single

Speed/ Double Speed

Protection : IP 55 / IP 66

Protected

Crane Control: Control

Pendent/Radio Remote

control



Manipulator



Product Range

Type – Pillar Mounted Manipulator

Power Source : Air/Hydraulic

Slewing : 360 Deg.

Manipulator Type – Semi

Automatic/ Fully Automatic

Attachment Type –

Pneumatic/Electric/Hydraulics

Protection : IP 55 / IP 66

Protected



Manipulator

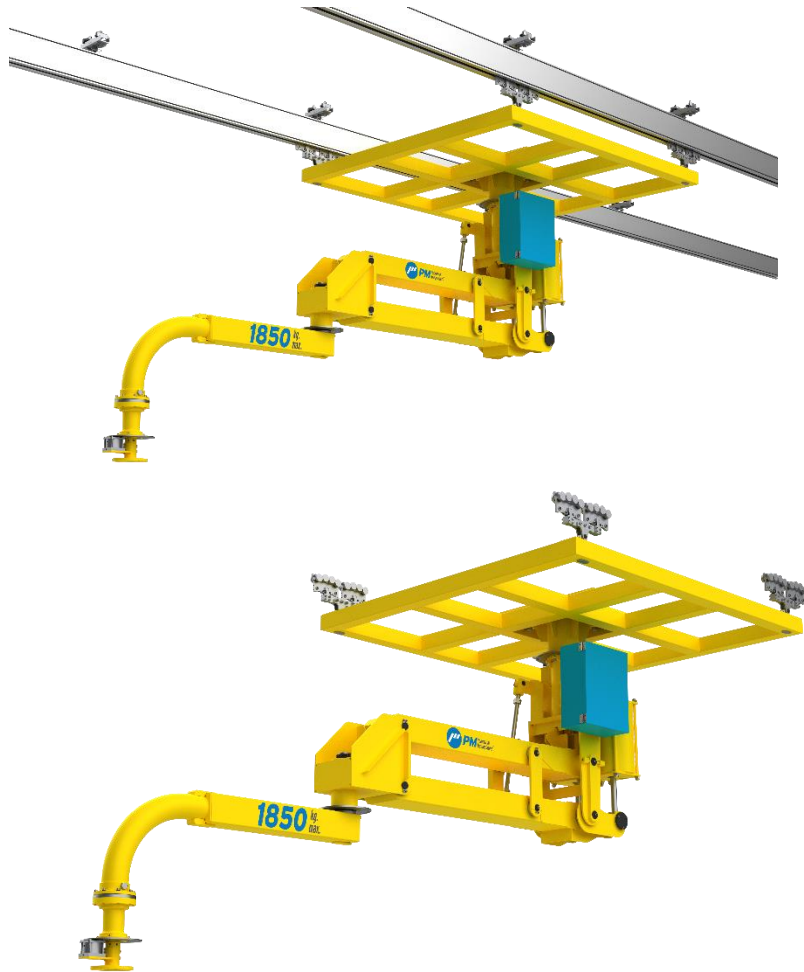

Product Range

Type – Overhead Mounted Manipulator

Power Source : Air/Hydraulic

Slewing : 360 Deg.

Manipulator Type – Semi Automatic/
Fully Automatic

Attachment Type –

Pneumatic/Electric/Hydraulics

Protection : IP 55 / IP 66 Protected



Articulated Type Jib Crane/Manipulator

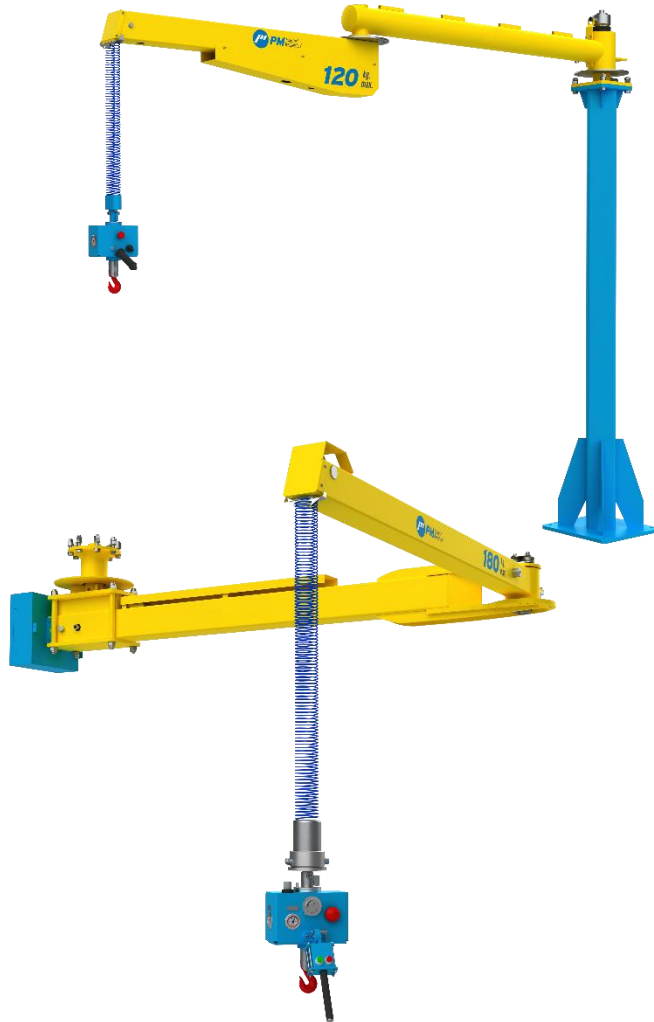

Product Range

Type – Articulated Jib Crane/ Manipulator

Power Source : Air/Electric

Slewing : 360 Deg.

Manipulator Type – Semi Automatic/ Fully Automatic

Attachment Type – Pneumatic/Electric

Protection : IP 55 / IP 66 Protected



Chain Hoist



 Kg	ISO	Type	STAR	EN818-7 DAT 	
Age				mm	mm/min
125	M7	125/1-8/2	031/53	5,2x15	8/2
250	M6	250/1-8/2	031/51	5,2x15	8/2
500	M6	500/2-4/1	031/51	5,2x15	4/1
	M5	500/1-8/2	071/54	7,2x21	8/2
1000	M5	1000/2-4/1	071/54	7,2x21	4/1
	M5	1000/1-6/1,5	071/55	7,2x21	6/1,5
1600	M5	1600/1-8/2	091/55	9x27	8/2
2000	M5	2000/2-3/0,75	071/55	7,2x21	3/0,75
2500	M5	2500/1-10/2,5	111/52	11,3x31	10/2,5
3200	M5	3200/2-4/1	091/55	9x27	4/1
5000	M5	5000/2-5/1,25	111/52	11,3x31	5/1,25

Wire Rope Hoist



Product Range

Capacity : 1 Ton to 50
Ton

Height of Lift : 6 Mtr to
30 Mtrs

Speed Type : Single

Speed/ Double Speed

Protection : IP 55 / IP 66
Protected

Crane Control: Control
Pendent/Radio Remote
control

Automation Product



Roller Conveyor



Slat Conveyor



Belt Conveyor

Tackle & Girpper



Wheel Handling Tackle



Vacuum Gripper



Adjustable Gripper



Scissor Type Lift Tackle



Lifting Tackle



Carton Box Lifting Tackle

Customer List





TOSHIBA



Factory Location



SPNJIT ENGINEERING SOLUTIONS PVT. LTD.

S-94, Site-II, Loni Road, Industrial Area, Mohan Nagar

Ghaziabad, U.P – 201007

Tel : 9811336657,

E-mail : marketing@spnjit.com, sales@spnjit.com

Website : www.spnjit.in,



Thank You